



SANDVIK CH440 CONE CRUSHER

TECHNICAL SPECIFICATION

Sandvik CH440 cone crusher is an advanced design, with a small footprint and high capacity in relation to size, and a hydraulically supported main shaft that is supported at both ends.

Sandvik CH440 is suitable for a high-capacity secondary application or a high-reduction tertiary or pebble-crushing application, and it can be matched to changes in production through the selection of crushing chambers and an eccentric throw. This flexibility means that it's suitable for a wide range of applications.

Sandvik CH440 is highly versatile and reliable, and is designed to be easily serviced so that you can maximize the uptime of the equipment.

The Automatic Setting Regulation control system (ASRi™) enables real-time performance management, giving you a machine that consistently runs at optimum levels.

Achieve optimal performance by selecting the Sandvik crushing chamber that's right for your application.

Several standard crushing chambers are available for each model. The crushers can easily be matched to changes in production by selecting the right chamber and eccentric throw.

The chambers available are:

- EF = Extra fine
- F = Fine
- MF = Medium fine
- M = Medium
- MC = Medium coarse
- C = Coarse
- EC = Extra coarse



KEY FEATURES

ASRi™	Automatically adapts crusher to feed conditions
Hydroset™ system	Provides safety and setting adjustment functions
Mainframe is built as a unibody without moving parts	For optimal strength and less components requiring maintenance
Top serviceability	Lifting from above minimizes risks, and allows for quicker and safer maintenance
Adjustable eccentric throw	To exactly balance capacity to the process thus harmonizing the crushing stages
Constant liner profile	Maintains the feed opening and performance during the entire service life of the liners
Wide range of crushing chambers suited for all types of applications	Choose from extra coarse crushing chambers with the largest intake to extremely fine crushing chambers
Hydraulic dump valve for tramp iron protection	Reduces pressure peaks and mechanical stress on the crusher, greatly improving reliability

GENERAL INFORMATION

GENERAL DESIGN CRITERIA

Crusher type	Cone crusher, hydraulically adjusted
Application	Construction, aggregate
Crushing stage	Secondary, tertiary, pebble
Max. feed size	47-250 mm
CSS range	4-48 mm
Nominal capacity*	58-336 mtph
Ambient temperature	-20°C to +40°C (Contact Sandvik if outside range)
Altitude of site	≤ 1,000 m (Contact Sandvik if outside range)

* Capacity is dependent on the crushing chamber, the eccentric throw, the crusher's setting and the feed material's bulk density, crushability, size analysis, moisture content, etc.

GENERAL CRUSHER DATA

Weight	16,620 kg
Main frame	Two-part unibody structure without moving parts. Cast steel.
Top shell	Two-arm design
Bottom shell	Three-arm design Two inspection hatches
Feed hopper	One inspection hatch
Feed level sensor	Available as option
Main shaft	Supported at both ends Top spider bearing and eccentric bearing
Eccentric bushings (Throws – mm)	• 16, 19, 22 • 22, 25, 29 • 29, 32, 34, 36
Eccentric speed	320 rpm
Max. motor power	220 kW
Drive	V-Belt
Safety coupling	N/A
Pinion shaft speed	1,485 rpm (50 Hz) 1,491 rpm (60 Hz)
Maintenance tool box	Extractor for eccentric bushing Extractor for bottom shell bushing Extractor for step bearing Additional lifting and maintenance tools included

CRUSHING CHAMBERS

Mantle alternatives	A, B, EF, FlexiFeed A/B, HC
Concave alternatives	EC, C, MC, M, MF, F, EF
Alloys for mantles and concaves	M1, M2, M7, M9
Mantle and concave backing material	Epoxy
Lifting tools for mantles and concaves	Available as option

CRUSHER DRIVE SYSTEM

MOTOR CHARACTERISTICS

Manufacturer	WEG
Model	W21/W22
Type	Three-phase, squirrel cage
Weight	1,330-1,538 Kg
Rated power	220 kW
Frequency	50/60 Hz
Poles	4
Vibration resistance	Motor is supplied with special winding that is reinforced in order to support the vibration levels
Insulation class	F
Protection class	IP55

CRUSHER DUST EXCLUSION

SYSTEM CHARACTERISTICS

Type	Over-pressure air system
Air input	Blower
Air quality	Filtered
Air flow	150 l/min
Air pressure	10kPa max
Weight (blower, hoses)	42 kg
Motor power	0.75 kW @50 Hz / @60 Hz
Motor speed	2,825 rpm (50Hz) 3,440 rpm (60Hz)
Phases	3
Insulation class	H
Protection class	IP55

CRUSHER WEAR PROTECTION

FEED HOPPER

No. of liners	N/A
Max. weight	N/A
Material	N/A
Fastening method	N/A

TOP SHELL LINER

No. of liners	4
Max. weight	60 kg
Material	Wear-resistant hardened steel
Fastening method	Hanging and/or bolted

TOP SHELL SPIDER CAP

Max. weight	160 kg
Material	Carbon steel
Fastening method	Bolted seal with O-ring

TOP SHELL ARM SHIELDS

No. of shields	2 (1 per spider arm)
Max. weight	43 kg
Material	Manganese steel
Fastening method	Welded

BOTTOM SHELL BODY LINERS

No. of liners	14
Max. weight	25 kg
Material	Wear-resistant hardened steel
Fastening method	Welded

BOTTOM SHELL ARM LINERS

No. of liners	3
Max. weight	44 kg
Material	Manganese steel
Fastening method	Welded

*No main frame welding

MANUALS

Operator's manual	Any language
Installation manual	Any language
Installation manual appendix	Any language
Maintenance manual	Any language
Spare parts catalogue	English only

TANK UNIT

GENERAL DATA

Purpose	Supplies oil to the crusher, lubrication system and Hydroset system
No. of doors	2
No. of inspection hatches	3
Cabinet material	Metal
Tank unit dimensions (L x W x H)	1,680 x 1,050 x 1,996 mm
Dry weight	825 kg

HYDROSET SYSTEM

System design	Single reversible pump
Oil tank reservoir capacity	85 liters
Pump design	Gear pump
Pump capacity	10.4 l/min @50 Hz 12.6 l/min @60 Hz

Oil filter

Filter type	Spin-on
Filtration grade	10 µm
Filter material	Glass fiber
No. of filters	1

Pump motor

Type	Three-phase, squirrel cage
Power	3.0 kW @50 Hz 3.6 kW @60 Hz
Speed	1,450 rpm @50 Hz 1,740 rpm @60 Hz
Insulation class	F
Protection class	IP55

MAIN CRUSHER LUBRICATION SYSTEM

System design	Closed circuit, single pump, gravity return
Oil tank reservoir capacity	400 liters
Pump design	Gear pump
Standby pump	N/A
Pump capacity	70 l/min @50 Hz 85 l/min @60 Hz

Oil filters

Filter type	Spin-on
Filtration grade	25 µm
Filter material	Glass fiber
No. of filters	1

Pump motor

Type	Three-phase, squirrel cage
Power	3.0 kW @50 Hz 3.6 kW @60 Hz
Speed	1,450 rpm @50 Hz 1,740 rpm @60 Hz
Insulation class	F
Protection class	IP55

Oil heaters

No. of heaters	1 (2 Option)
Type	Immersion heater
Rating	1.65 kW
Installation type	Immersion heater tube
Phases	3

PINIONSHAFT LUBRICATION SYSTEM

System design	Closed circuit, bleed off line from main lubrication, gravity return
Oil tank reservoir capacity	N/A
Pump design	N/A

Oil filter

Filter type	Spin-on
Filtration grade	10 µm
Filter material	Glass fiber
No. of filters	1

Pump motor

Type	N/A
Power	N/A
Speed	N/A
Pump capacity	N/A
Insulation class	N/A
Protection class	N/A

TANK OVER-PRESSURE AIR SYSTEM

Type	N/A
Air input	N/A
Air quality	N/A
Air flow	N/A
Air pressure	N/A
Weight (blower, hoses)	N/A

Tank air blower motor

Power	N/A
Speed	N/A
Insulation class	N/A
Protection class	N/A
Phases	N/A

CRUSHER TRAMP IRON PROTECTION

ACCUMULATOR

System description	Protection against uncrushable objects by redirecting Hydroset-oil into a pressurized accumulator
--------------------	---

MECHANICAL DUMP VALVE

System description	N/A
--------------------	-----

ELECTRIC DUMP VALVE

System description	N/A
Pressure transmitter and an electric pilot valve connected to a dedicated, rapid sampling PLC system	
Hydraulic pressure sampling rate	N/A
Heating elements	N/A

PLC CABINET

Manufacturer	N/A
Dimensions (L x W x H)	N/A
Weight	N/A
Supply voltage	N/A
Phases	N/A
Frequency	N/A
Power	N/A
Protection class	N/A
Control voltage	N/A
Communication interface	N/A
Customer feedback signals	N/A

OIL COOLING SYSTEMS (FOR MAIN CRUSHER LUBRICATION)

STANDARD AIR/OIL COOLERS

No. of units	1
Dry weight (incl. stand)	130 kg
Material	Aluminum
Oil volume	12.9 liters
Max. air flow	2,8 kg/s @50 Hz 3,4 kg/s @60 Hz

AIR COOLER FAN MOTOR

Type	Three-phase, squirrel cage
Power	2.2 kW @50 Hz 3.6 kW @60 Hz
Speed	1,450 rpm @50 Hz 1,740 rpm @60 Hz

WATER/OIL COOLER (OPTION)

No. of units	N/A
Dry weight (incl. stand)	N/A
Heat exchanger material	N/A
Oil volume	N/A
Bypass pressure	N/A
Waterflow rate	N/A
Inlet water temperature	N/A
Max. water feed pressure	N/A
Max. cooling capacity	N/A

OFFLINE FILTER UNIT FOR MAIN LUBRICATION

Purpose	Removes particles and water from the main lubrication system in a continuous slow offline filtration process
Model	27/54
Oil capacity	20 liters
Dimensions (L x W x H)	650 x 450 x 1,055mm
Weight	100 kg
Pump design	Gear wheel

OIL FILTER

Filter type	Filter Insert
Filtration grade	3 µm
Filter material	Cellulose
Filter housing material	Cast iron
No. of filters	2

PUMP MOTOR

Type	Three-phase, squirrel cage
Capacity	200 l/h @50 Hz 240 l/h @60 Hz
Speed	915 rpm @50 Hz 1,120 rpm @60 Hz
Protection class	IP55

AUTOMATIC SETTING REGULATION - INTELLIGENT (ASRi)

ASRi is Sandvik's control system used in crushing and screening applications.

The ASRi keeps the setting as close as permitted by the machine without risk of damaging it. Thus, the ASRi helps the user achieve higher production, a higher degree of reduction, and improved product distribution. In addition, a better product shape can be obtained. A further benefit is that the cone crusher's wearing liners can be utilized better.

The ASRi monitors the cone crusher's performance and ensures that the measured values lie within the permitted limits that have been set in the system. If these limits are exceeded, the ASRi will adjust the setting until the desired values are attained.

MONITORING FUNCTIONS (AVAILABLE WITH METRIC AND IMPERIAL UNITS)

Power consumption
Hydroset hydraulic pressure
Main shaft position
Calculated CSS (based on main shaft position)
Liner wear
Historical data log
Automatic liner wear compensation

REGULATING FUNCTIONS AND CRUSHING PROGRAMS

Auto-CSS	Keep CSS constant
Auto-Load	Keep load constant (automatic compensation for liner wear)
Multi-CSS	Alternate between two CSS settings
20 customized programs can be stored	

SAFETY FUNCTIONS

Protects the crusher from overload by automatically regulating the crusher based on preset operational values and the real-time input from the crusher

Alarm severity levels: Direct Stop of Feeder and Regulating, Feeder Stop, Warning

Signal permitting operation of the crusher drive motor

Alarm log

HARDWARE COMPONENTS

CONTROL UNIT / OPERATOR'S PANEL

Dimensions (wall mount) (H x W x D)	358 x 290 x 70 mm
Dimensions (panel mount) (H x W x D)	350 x 290 x 88 mm
Weight (wall mount)	6.5 kg
Weight (panel mount)	5.6 kg
Operational temperature	-20°C to +50°C
Protection class	IP65
Protection class (panel mount)	IP65 (front), IP30 (rear)
Power supply	18 - 32 VDC
Communication	Ethernet, RS232, COMLI, XNL

POWER SUPPLY UNIT

Dimensions (H x W x D)	217 x 120 x 72 mm
Weight	2.7 kg
Operational temperature	-25°C to +70°C
Protection class	IP67
Power supply	100 - 240 VAC

POWER MEASUREMENT UNIT

Dimensions (H x W x D)	130 x 70 x 135 mm
Weight	0.6 kg
Operational temperature	-25°C to +60°C
Protection class	IP20
Power supply	85 - 250 VAC

HYDROSET DRIVE UNIT

Dimensions (H x W x D)	320 x 320 x 160 mm
Weight	9.5 kg
Operational temperature	0°C to +50°C
Protection class	IP65, IP20
Power supply	100 - 240 VAC

TANK MEASUREMENT UNIT

Dimensions (H x W x D)	211 x 30 x 26,5 mm
Weight	0.266 kg
Operational temperature	0°C to +55°C
Protection class	IP67
Power supply	24 VDC via ASRi bus

ASRi BUS

ASRi bus speed	38,400 Bd
Update frequency CBT	50 - 60 Hz
Update frequency U1N	25 - 30 Hz
Update frequency L3	5 - 6 Hz

SOFTWARE PACKAGE (OPTIONAL)

Operating system compatibility: Windows 10, Windows 8, Windows 7, Windows Vista, Windows XP, Windows 2000	
WINi	Simultaneously control up to 9 different crushers with ASRi / ACS from a PC via Ethernet network. Control the ASRi remotely using the same graphical user interface.
OPC Server	Make it possible to transfer variable values between one or more ASRi system(s) and one or more client application(s).
ASRi Reporter	Export data from the ASRi to a PC for analysis and storage.

PERFORMANCE

CH440 – NOMINAL CAPACITY* (MTPH)

	Concave	EC	C	MC	M	MF	F	EF
Max. feed size (mm)	F85**	141	115	80	-	-	-	-
	F90	171	140	126	99	78	66	37
	F100	250	204	157	124	98	83	47
Max. motor power (kW)		220	220	220	220	220	220	220
Eccentric throw (mm)		16-44	16-44	16-44	16-44	16-44	16-44	16-44
CSS (mm)	4	-	-	-	-	-	-	58-110
	5	-	-	-	-	-	-	60-106
	6	-	-	-	-	-	-	62-110
	8	-	-	-	-	-	80-101	66-108
	10	-	-	-	-	-	85-162	70-106
	13	112-155	108-151	118-180	125-222	108-207	92-175	76-95
	16	121-230	117-223	128-243	135-257	117-223	99-189	82-92
	19	129-247	126-239	137-261	145-276	126-239	107-203	-
	22	138-263	134-256	146-279	154-294	134-256	114-217	-
	25	147-280	143-272	156-297	164-313	143-272	121-231	-
	29	159-303	154-294	168-299	177-292	154-254	131-215	-
	32	168-320	163-289	177-292	187-260	163-226	138-192	-
	35	176-336	171-282	187-259	197-248	171-216	145-183	-
	38	185-329	180-250	196-247	207	180	153-172	-
	41	194-295	188-237	205	-	-	-	-
44	203-282	197	-	-	-	-	-	
48	215-242	-	-	-	-	-	-	
Mantle	A/B/FF-A/ FF-B	A/B/FF-A/ FF-B	A/B/FF-A/ FF-B	A/B	A/B	A/B	EF	

* based on material with bulk density of 1,600 kg/m³

** Additional feed size requirement applicable for FF mantle only (FlexiFeed)

WEIGHT (KG)

	Kg	Lb
Top shell assembly	5,232	11,535
Bottom shell assembly	4,701	10,363
Main shaft assembly	3,821	8,424
Pinion shaft housing assembly	262	578
Hydroset cylinder assembly	914	2,015
Feed hopper assembly	503	1,109
Eccentric assembly	803	1,769
Dust collar assembly	214	472
Hoses and protection assembly	19	42
Crusher weight	16,617	36,633
Subframe	1,493	3,292
Electric motor (max.)	1,538	3,390
Total weight (incl. subframe and drive)	19,648	43,315

DIMENSIONS

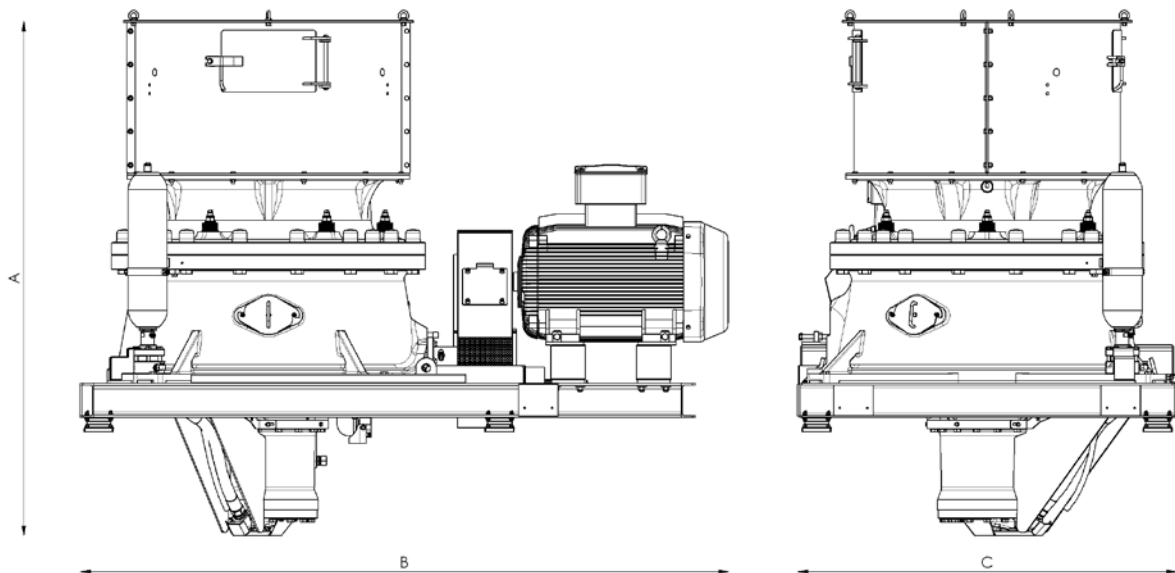

A	3,000 mm
B	3,806 mm
C	2,190 mm

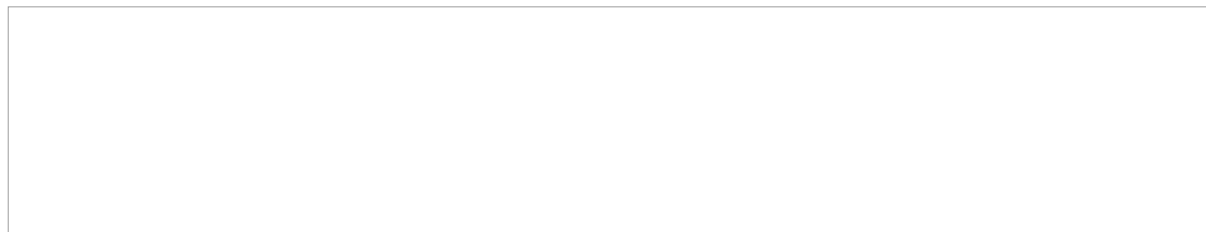

Sandvik Mining and Rock Technology reserves the right to make changes to the information on this data sheet without prior notification to users. Please contact a Sandvik representative for clarification on specifications and options.